



**MARCEGAGLIA**  
**BUILDTECH**

**GENERAL TERMS AND  
CONDITIONS OF SALE**  
according to  
**AIPPEG UX120**



**UNICMI**

**DIVISIONE  
AIPPEG  
Pannelli ed  
elementi grecati**

# UX120

## **General Terms and Conditions of Sale of insulated metal panels, corrugated sheets and accessories**

Document updated on 03/08/2023

### **Warnings**

It is advised to check the Editorial Products Area of the [www.unicmi.it](http://www.unicmi.it) website for the latest version of this document. The considerations contained in this document are the result of summarising and interpreting regulations, laws and official documents. However, it is advisable to refer to the relevant integral texts and regulations mentioned therein. In the absence of written authorisation from UNICMI, neither the reproduction nor the dissemination by any means whatsoever of this document or parts thereof is permitted, and UNICMI declines all liability for unauthorised use.

# CONTENTS

1. BACKGROUND .....	5
2. PARTIES TO THE CONTRACT .....	5
3. ORDER - ACCEPTANCE .....	5
4. DELIVERY, SHIPMENT AND TRANSPORT OF MATERIALS .....	5
5. PACKAGING AND PROTECTION .....	6
6. TOLERANCES .....	7
7. RECOMMENDATIONS AND INSTRUCTIONS .....	7
8. GUARANTEES .....	8
9. PRICE REVISION .....	9
10. PAYMENTS .....	10
11. WITHDRAWAL FROM THE CONTRACT .....	10
12. RESERVATION OF TITLE .....	11
13. REGULATORY STANDARDS .....	11
14. COMPETENT COURT .....	11
15. DATA PROCESSING .....	11

## **ANNEX A - RULES ON THE HANDLING, MANIPULATION AND STORAGE OF INSULATED METAL PANELS, CORRUGATED SHEETS AND ACCESSORIES**

1. PACKING AND PACKAGING .....	12
2. TRANSPORT .....	13
3. STORAGE .....	13
4. LIFTING AND HANDLING .....	15

## **ANNEX B - QUALITY STANDARDS OF INSULATED METAL PANELS AND CORRUGATED SHEETS**

## **ANNEX C - RECOMMENDATIONS FOR THE INSTALLATION OF INSULATED METAL PANELS AND CORRUGATED SHEETS**

1. BACKGROUND .....	25
2. CONSTRUCTION ELEMENTS .....	25
3. PRELIMINARY OPERATIONS .....	27
4. ROOFS .....	27
SLOPES .....	27
ASSEMBLY SEQUENCES .....	27
A) Plain corrugated sheet metal and prefabricated monolithic sandwich (types 1.1.1 and 1.2.1) .....	27
B) Sandwich prepared on the construction site (type 1.1.2) .....	28
B.2) Crossed corrugated sheet sandwiches .....	29
C) Deck prepared on the construction site (type 1.1.3) and Pre-insulated Deck (type 1.2.2) .....	29
5. WALLS .....	29
ASSEMBLY SEQUENCES .....	29

A)	Plain corrugated sheet metal and prefabricated monolithic sandwich (types 2.1.1 and 2.2.1) .....	29
B)	Sandwich prepared on the construction site (type 2.1.2) .....	30
B.2)	Crossed corrugated sheet sandwiches.....	30
<b>6.</b>	<b>FLOORS.....</b>	<b>31</b>
	ASSEMBLY SEQUENCES.....	31
A)	Plain sheet metal (type 3.1) .....	31
B)	Sheet metal with collaborating concrete (type 3.2).....	31
C)	Corrugated sheet metal as non-recoverable formwork (type 3.3) .....	31
<b>7.</b>	<b>FASTENERS.....</b>	<b>31</b>
	For roofs: .....	31
	For walls: .....	32
	For floors:.....	32
	Fastening on metal carpentry: .....	32
	Fastening on woodwork:.....	32
	Fastening on reinforced concrete and prestressed concrete: .....	32
<b>8.</b>	<b>FINISHING ELEMENTS.....</b>	<b>32</b>

**ANNEX D - INSTRUCTIONS FOR THE INSPECTION AND MAINTENANCE OF ROOFS AND WALLS MADE OF INSULATED METAL PANELS AND CORRUGATED SHEETS**

<b>1.</b>	<b>INSPECTION.....</b>	<b>33</b>
<b>2.</b>	<b>MAINTENANCE.....</b>	<b>34</b>

## 1. BACKGROUND

This document contains the general sales conditions for insulated metal panels, corrugated sheets and accessories.

Any additional conditions and further specifications with respect to the basic document shall be an integral part of the contract concluded between the Seller and the Buyer.

## 2. PARTIES TO THE CONTRACT

The Seller party shall be understood to be the company producing and/or supplying the goods in question, which shall issue an invoice for the same goods. The Buyer Party is understood to be the holder of the invoices for the goods in question.

## 3. ORDER - ACCEPTANCE

The Buyer's order has the value of a proposal and is irrevocable for the duration of 30 (thirty) days. The Seller's confirmation shall have the value of acceptance and is the only document that binds the parties and governs the contractual relationship, as far as not provided for in these "**General Terms and Conditions of Sale**".

For the purpose of acceptance of the order, the date indicated in the postmark or in the e-mail/certified e-mail of dispatch of the confirmation shall apply.

In the event that the confirmation provides for the supply of items belonging to different types and/or split deliveries, each type and/or delivery shall be considered contractually independent of the others.

If the Seller's Order Confirmation contains changes with respect to the Order, such changes shall be deemed automatically and tacitly accepted by the Buyer 3 (three) working days after receipt of such Order Confirmation, without the Buyer having expressed his dissent to the Seller in writing within that period.

For small quantities of products ordered by the Buyer, which are to be combined with other orders with the same type of product (so called "Production Combination"), the delivery date indicated is to be considered as indicative only. Without prejudice to the provisions of Article 4 below, the Seller shall, within 30 (thirty) days of sending the Order Confirmation to the Buyer, confirm in writing the delivery date determined on the basis of the production campaign in "Production Combination". In the absence of such notice, the Buyer shall be entitled to revoke the order by giving written notice to the Seller - under penalty of forfeiture of the right of revocation - within the following 3 (three) days. It follows that in the absence of such notice of cancellation by the Buyer within the aforementioned period of 3 (three) days, the delivery date communicated by the Seller shall be accepted without the Buyer therefore being able to raise any claim or dispute.

## 4. DELIVERY, SHIPMENT AND TRANSPORT OF MATERIALS

The *Seller* undertakes to comply with the agreed delivery terms; however, an allowance of 15 (fifteen) working days is permitted (barring unforeseen circumstances).

Events preventing or delaying the production of the goods, such as, but not limited to, strikes (including company strikes), lockouts, fires, import bans, delayed supply of raw materials or limitations of energy sources, and other events preventing or delaying manufacture, are conventionally considered force majeure and the Seller shall not be held liable for any delay in delivery.

In the aforementioned cases, the *Seller* may delay delivery as long as the causes of delay last.

Should the causes of delay last longer than 30 (thirty) working days, the *Seller* shall have the right to withdraw from the contract, without this implying the *Buyer's* right to compensation for damages directly or indirectly attributable to the delay.

Upon expiry of the agreed delivery terms, within 15 (fifteen) calendar days from receipt of the notice of readiness, the *Buyer* shall collect the ordered goods, or, in the case of delivery at destination, shall request their shipment.

After this term, the items may be stored outdoors, releasing the *Seller* from any liability, with forfeiture of all guarantees and with the charge of handling and storage costs to the extent of 1% of the value of the items for each week of storage; the *Seller* also reserves the right to ship the items freight collect to the *Buyer*, or to deposit them at the *Buyer's* expense.

After 8 (eight) days from the issue of the notice of ready goods, a regular invoice will be issued and the payment terms will commence.

Furthermore, whenever the *Buyer*, in order to contain transport costs, requests in the Order that the delivery of the Products ordered by it is carried out by the *Seller* in combination with the delivery of other products ordered to the *Seller* by third parties (the "Combined Transport"), the delivery date indicated by the *Seller* in the Order Confirmation shall be considered merely possible and indicative and the *Seller* shall be entitled to postpone the delivery of the relative Products until such time as it has received a total quantity of Combined Transport orders sufficient to justify their shipment.

The *Buyer* is obliged to check the items upon delivery. The items, even if sold free at destination, always travel at the *Buyer's* risk.

Any apparent defects and shortages must be reported at the time of delivery, under penalty of forfeiture of the relevant guarantee, by annotation on the delivery note, countersigned also by the carrier, and promptly sent to the *Seller*.

The panel, produced on a continuous line, is cut to size using band saws or, in some cases, disc saws. Known technologies do not allow metal substrates to be cut without deburring. Therefore, an apparent defect cannot be claimed since it is not a product defect. Such debris can be easily removed during installation and does not constitute a defect of the item.

The presence of foam residue on the metal surface may also not be considered an apparent defect. This can take place after removal of the insulation to allow for the longitudinal overlapping of the elements in the case of so-called "overlapping". The removal of bare metal shall, in any case, be completed on site during the installation phases and shall be the responsibility of the *Buyer*, not constituting a defect in the article.

In the aforementioned cases, therefore, no financial recognition and/or compensation is provided for any direct or indirect costs incurred by the *Buyer*.

The operations referred to in **Annex A** of these **AIPPEG General Terms and Conditions of Sale**, as well as unloading and assembly operations, regardless of the point of return of the goods, unless otherwise agreed, are carried out at the *Buyer's* care and responsibility, scrupulously following the instructions provided in this regard by the *Seller*.

Any parking, warehousing or waiting costs shall be borne by the *Buyer*, even if the items are sold free at destination and transport takes place with means of transport of the *Seller* or commissioned by the *Seller*.

## 5. PACKAGING AND PROTECTION

The materials are generally supplied unpacked. Packaging must be requested when placing the order and will be charged to the invoice. In this case, the choice of the type of packaging and the verification of the suitability of it with respect to the specific characteristics of the product purchased, the methods of transport and the handling and vehicles/equipment used on site, as well as all the responsibilities resulting from such a choice are entirely and exclusively the responsibility of the *Buyer*, with the express exclusion of any and all responsibility of the *Seller* in this regard.

In order to ensure the aesthetic integrity of the panels and pre-painted corrugated sheets, it is essential that these surfaces are covered with a protective film during manufacture, handling, transport and assembly. This film can be removed during installation. The *Buyer* requesting or accepting the supply of panels or pre-painted corrugated sheets without such protection shall assume all liability and shall in fact indemnify the *Seller* for any damage and/or imperfections resulting from such surfaces.

In order to prevent damage and/or imperfections on the surfaces of the products, or complications in the removal phase, the *Seller* recommends the *Buyer* to remove the protective film within 15 (fifteen) days from the date of "notice of ready goods" and in any case, pending installation, to store the panels in accordance with the procedures specified in **Annex A** of these **AIPPEG General Terms and Conditions of Sale**.

In fact, numerous experiences show that a long stay on site, in the open air, without strict observance of the handling and storage methods can lead to the onset of phenomena of excessive adhesion of the film, difficulties in removing it, and sometimes unexpected interactions with the underlying organic coating.

In the absence of strict adherence to the aforementioned measures at the construction site, any claims for alleged defects in the adhesive film and/or consequences directly and/or indirectly related to this film will not be accepted by the *Seller*.

In the sole case in which the *Buyer* proves to have concretely adopted all suitable measures on the building site, the claim for defects attributable to the film shall be presented within the terms and according to the procedures specified in **section 7** below; the lack of timeliness of the claim and/or the use and/or installation of the manufactured item, even in the presence of a timely claim, effectively preventing the *Seller* from verifying the alleged problem, shall cause the *Buyer* to forfeit the warranties indicated below.

Should the *Seller* acknowledge the existence of the defect, the quantification of the damage suffered by the *Buyer* shall in any case not exceed the value of the sales price of the protective film ordered by the *Buyer*.

## 6. TOLERANCES

The *Buyer* accepts the tolerances given in the catalogues and/or data sheets made available by the *Seller* (latest edition).

## 7. RECOMMENDATIONS AND INSTRUCTIONS

The *Buyer* acknowledges and expressly takes note of the fact that all materials used in the construction of roofs and walls, especially metals, are subject to the phenomenon of thermal expansion due to changes in temperature. The stresses resulting from this effect in the sheets act on the panel plane and can cause functional and aesthetic anomalies in the Product, particularly in the case of one or more of the following characteristics

- relevant panel length ( $L > 5$  metres);
- high radiation;
- dark colours ( $R_G = 8-39$ , EN 14509:2013);
- inadequate thickness of the metal support;
- polyurethane foam insulation core, in particular polyisocyanurate, linear support

For high values of surface temperature, linear elongations of the external metal support, with respect to that inside the structure or to any other constraint, generate stresses that are discharged in the vicinity of the profile's section changes due to the change in shape. The phenomenon can be accentuated by cyclic temperature changes associated with day-night or freeze-thaw excursions, which cause uncontrollable cyclic stresses that lead to additional fatigue loads on the supporting elements. It is therefore the responsibility of the *Buyer* and/or its designer to calculate the deformations and how to apply the product under such conditions, in order to avoid tensions that may cause imperfections and undulations on metal substrates with the formation of wrinkles and bubbles.

Risks can be minimised by adopting the following prescriptions:

- Avoid dark colours ( $R_G = 8-39$ , EN 14509:2013) for long panel lengths ( $L > 5000$  mm);
- Use suitable metal substrate shims (min. 0.6 mm to be assessed according to project specifications);
- Segmenting the panels;
- Adopt a suitable type and texture of fixing, especially for roofing panels;
- Use a fastening of the panels to the wall that is able to compensate for displacements caused by excessive thermal expansion; this is particularly important when using panels with aluminium supports

Therefore, as an express derogation to any other provisions (and without prejudice to the fact that the calculation of deformations, the manner of application of the Products, as well as the types of weaving and fastening necessary, on a case-by-case basis, to avoid tensions that may cause imperfections and undulations with the formation of bubbles and wrinkles, are left exclusively to the *Buyer* and/or its designer), no warranty is given by the *Seller* in relation to the foregoing, including, in particular

- (i) the possible presence - in panels with substrates having nominal thickness of less than 0.5 mm - of surface imperfections such as bumps, local instabilities, undulations, etc;
- (ii) the possible presence - in panels with stainless steel supports - of cutting burrs and/or imperfections on the surface, instabilities, undulations, etc;
- (iii) the possible presence on the surface of the panels - in the event of installation that does not comply with the Seller's technical specifications (data sheets and/or manuals), or expressly advised against by the Seller - of local instabilities, undulations and/or imperfections, even if they are likely to affect the overall aesthetics of the work;
- (iv) the possible presence - in the case of installation of panels with dark-coloured external support in multi-span - of non-homogeneous surface flatness;
- (v) any failure to achieve fire performance due to the Buyer's (or third party's) failure to comply with the conditions contained in the relevant classification and test reports.

The Seller shall not be liable to the Buyer (with the consequent termination of any form of guarantee, whether legal or conventional) in relation to any defects and/or non-conformity of the Products that are a consequence of the failure to comply, even partially, by the Buyer or third parties with the above provisions; in such cases, therefore, the Buyer's right to terminate the contractual relationship established with the Seller is expressly excluded.

## 8. GUARANTEES

The products must be used in strict compliance with the *Seller's* technical documentation, and the guarantee will therefore be voided if the products are applied in a manner that does not comply with the technical documentation or if installation diagrams are used that do not comply with the *Seller's* technical data sheets (latest edition).

Complaints of any kind, with the exception of those indicated in **section 4** above, must be made formally in writing to the Seller within 8 (eight) days of receipt of the products, the *Buyer* being understood to have forfeited, after this term, any right to warranty for defects and/or lack of quality and/or non-conformity of the products sold. In any event, the provisions of **Article 1495 of the Italian Civil Code** concerning limitation periods shall apply.

Complaints must be substantiated and adequately accompanied by descriptive documentation (photos and videos) to enable the *Seller* to carry out a prompt and complete check. The items subject to claim shall be kept at the *Seller's* disposal, in the state in which they were delivered, in compliance with the "*handling, manipulation and storage rules*" specified in **Annex A** to these "**General Terms and Conditions of Sale**" and any special instructions provided by the *Seller*.

In the event that the *Seller* determines that the products are found to be unfit, the guarantee shall be fulfilled by repair or replacement and return at the contractually agreed point according to the type and extent of the damage.

In any case, items with obvious defects of any kind (and even more so obvious defects) shall not be used by the *Buyer* in any way whatsoever; therefore, they shall not be lifted up, fastened to the supporting structure, cut, etc. Failing this, the *Buyer* shall forfeit all warranties.

The *Buyer's* right to terminate the contract is excluded, as is the *Seller's* liability for any direct and/or indirect damages suffered by the *Buyer*, subject to the limit provided for in *Article 1229 of the Italian Civil Code*.

In the case of delivery by instalments, any claims, even if timely, shall not release the *Buyer* from the obligation to take back the remaining quantity of ordered goods.

The *Seller* guarantees the functional, i.e. not aesthetic, conformity of the items sold to the specifications contained in its catalogues and/or data sheets (latest edition).

If the *Seller*, at the written request of the *Buyer*, ascertains the presence of defects and/or faults not detectable at the time of delivery, thus also in the event that the products have been used and/or assembled by the *Buyer*, the guarantee shall be discharged, at the *Seller's* option:

- by performance of remedial works by the *Seller*;

or

- agreeing, in writing, to contribute to the costs of restoring suitability, which shall in no case exceed the original price of the defective material.

For items coated with organic material, the guarantee for the coating itself is discharged at the *Seller's* option as



follows:

- by execution of remedial works by the *Seller*
- or
- with the contribution to the repair costs in an amount not exceeding three times the original price of the organic coating affected by defects; the amount of the contribution to costs, as determined above, will be progressively reduced in proportion to the period of use of the delivered product.

In any event, the *Seller's* guarantee for such items shall not exceed the limits set by the guarantee issued by the supplier of the organic coating.

For articles with an organic coating, the *Buyer* must ensure proper storage on site in accordance with **Annex A** below in order to prevent premature oxidation of the zinc; such oxidation can lead to the formation of blisters, which are the main cause of the detachment of the organic coating during the removal of the protective film. In the absence of concrete evidence of proper storage and handling of the article by the *Buyer*, the *Seller* shall not be able to fulfil the aforementioned guarantee.

For metal surfaces without an organic coating, the *Seller* makes no warranty other than that they comply with applicable standards; the *Seller* is exempt from any liability in respect of the occurrence of oxidation phenomena, since these are probable phenomena.

The *Seller's* warranty, including for repaired and/or replaced parts, shall be provided within and not beyond the limits specified in **Article 1495 of the Italian Civil Code**.

The *Seller* assumes no liability in the event of repairs carried out by third parties.

Particular warranties and/or certifications may be issued, at the *Seller's* discretion, only if specifically requested by the *Buyer* when placing the order and specifically accepted in the *Seller's* order confirmation. All warranties shall be forfeited both for use that does not comply with the "performance" characteristics, and for failure to comply with the "*Handling, Manipulation and Storage Rules*" specified in **Annex A** and any special instructions provided by the *Seller*, and for the use of accessories functional to the use of the products (such as: fastening systems, buffers, drain stoppers, ridges, flashings, etc.) not supplied and/or not expressly approved by the *Seller*.

The calculation data, table values, bills of materials, graphic drawings, technical data on the fastening systems, as well as any other document provided by the *Seller*, shall be considered as mere orientation elements and shall not entail any liability by the *Seller*, remaining, by definition and legislation, the design, supervision of works and testing of the works the exclusive pertinence, responsibility and care of the *Buyer*.

Unless otherwise expressly agreed upon in writing with the *Seller*, the items to be supplied do not contribute in any way to the overall or partial stability of the building structure; they are therefore not suitable for bearing permanent static loads (vertical-horizontal), excluding their own weight. In fact, they rest on an existing load-bearing structure, which must have been suitably calculated and deemed suitable by the *Buyer* for the positioning and installation of the items, which only perform the function of covering/coating and/or improving the energy level of the building.

The *Seller* does not recognise any other use of the products other than those explicitly indicated in the technical documentation made available by it.

If the objections prove to be groundless, the *Seller* shall charge the costs of inspections and any expert opinions, including those of third parties.

The *Seller* reserves the right to make such changes or technical improvements to its production as it deems necessary.

The right of recourse of the *Buyer* who has resold to a third party, as provided for in Article 131 of Legislative Decree No. 206 of 2005, is expressly excluded.

## 9. PRICE REVISION

Prices are calculated on the basis of the costs in force on the date of the confirmation of sale.

The *Seller* reserves the right to modify the price of the Products, even after the Order Confirmation, should there

be an increase of more than 2% in the cost of labour and/or raw materials; in this case, in adjusting the price of the Products according to the variations in the cost of labour and/or raw materials, the Buyer expressly acknowledges that each of the factors listed below has a percentage impact on the composition of the price of the Product to the extent indicated below:

Type of Product	Incidence of labour costs	Incidence of metal cost	Incidence of component cost
Corrugated sheets	10%	90%	-
Sandwich panels	10%	50%-	40%

Reference will be made when determining the change in labour and raw material costs:

- for labour: to A.N.I.M.A. tables;
- for metals: to the Milan Chamber of Commerce price list;
- for insulation components and other raw materials: to the Seller's Supplier's certificate.

For accessories, the revision will be carried out conventionally by applying any changes in the official ISTAT cost-of-living index.

In the event of split deliveries, the price revision will only be applied to Products delivered after the increases have taken place.

Modifications in the prices of the Products introduced by the Seller will be communicated in writing by the Seller to the Buyer, who will have the right to withdraw from the relative Order, limited only to the part that has not yet been carried out, by giving written notice to the Seller (by registered letter with return receipt in advance by fax), under penalty of forfeiture, within 2 (two) days following receipt of the price variation communication transmitted by the Seller. In such cases, however, the Buyer shall be obliged to reimburse the Seller for all duly documented costs incurred by the latter up to the time of cancellation to procure, process and work the materials necessary to fulfil the Order subsequently cancelled by the Buyer."

## 10. PAYMENTS

Payments shall be made at the *Seller's* premises.

In the event of default by the *Buyer* (by way of example: cancellation of the order after the *Seller's* acceptance; failure to collect the items within the agreed time; change of the contractual conditions, etc.), the sums paid into the account shall be retained by the *Seller* as a down payment, without prejudice to the right to compensation for any further damages; in the event of default by the *Seller*, the amount paid into the account by the *Buyer* shall be returned, excluding any right to compensation for any further damages.

In the event of payments made late, the *Buyer* shall pay, pursuant to *Legislative Decree No. 193 of 9.11.2012 (Amendments to Legislative Decree No. 231/02)*, interest on arrears, in addition to compensation for costs, at the official reference rate increased by eight points, starting from the dates on which the agreed term expires.

Any claims or disputes, whether raised by way of action or exception, do not give rise to a suspension of payments.

If payment for the goods is to be made by bills of exchange or by means of securities (cheques, bills of exchange, etc.), these shall be received at the *Seller's* premises before or at the same time as collection of the goods.

In the event of non-payment on the due date of even a single part of the price, the *Buyer* shall forfeit the benefit of deferred payment ("*benefit of the term*") also for ongoing supplies; the *Seller*, moreover, may invoke the application of Articles 1460 and 1461 of the Italian Civil Code.

The statement of account sent by the *Seller* shall be deemed accepted by the *Buyer* if it has not been contested within 15 (fifteen) days of receipt.

## 11. WITHDRAWAL FROM THE CONTRACT

In addition to the cases provided for in **section 4** above, the *Seller* reserves the right to withdraw from the contract without charge in the event of facts or circumstances that alter the stability of the markets, the value of money, the

conditions of the industries producing the raw materials and the conditions of supply.

The *Seller* shall also have the right to withdraw from the contract at no charge if it becomes aware of dangers of serious prejudice, of the existence of protests of securities, and of the initiation of monitoring, ordinary, insolvency or extra-judicial legal proceedings against the *Buyer*.

Unless otherwise provided for in the General Terms and Conditions of Sale, under no circumstances may the Buyer withdraw prematurely from the Order or in any case be released from the obligations assumed and in particular from the obligation to make payment of the price to the extent and on the due dates agreed.

The Seller shall have the right to terminate, pursuant to art. 1456 of the Italian Civil Code, the Order concluded with the Buyer, upon written notice to the latter, in the event of the Buyer's omission or delay in making the payments due and the Buyer's failure to take delivery of the Products within the agreed terms.

## 12. RESERVATION OF TITLE

The Products supplied by the Seller remain the property of the Seller until full payment of the relevant price by the Buyer.

The delivery of the Products shall entail the identification of the goods and the simultaneous transfer of risks to the Client, who - for as long as the Seller's retention of title lasts - shall therefore be fully responsible towards the Seller for (and shall indemnify and hold the latter harmless from) any damage, loss, cost, expense, risk or liability that may be incurred by the Seller directly or indirectly as a result of, or in connection with, the use or disposition of the Products by the Customer or any third party, or the loss of or damage to the Products (for any reason whatsoever, including in the event of the transformation, installation or processing of the Products or their incorporation into other products of the Customer or any third party).

The Buyer shall bear all costs and expenses of registration of retention of title, if any, as required by the law of the country in which the Products are located.

The Buyer may not transfer ownership of the Products to a third party until the price thereof has been paid in full.

The Buyer shall notify the Seller in writing, within the next 24 hours, of any enforcement or precautionary action taken by third parties on the Products covered by the retention of title. The Buyer shall, in any event, indemnify and hold the Seller harmless from any costs or damages that may be incurred by the latter as a result of such enforcement or precautionary actions brought by third parties on the Products.

## 13. REGULATORY STANDARDS

Anything not expressly governed by these "**General Terms and Conditions of Sale**" shall be governed by the rules on sale as specified in **Articles 1470** et seq. of the Italian Civil Code, also in the case of the supply of goods on site.

## 14. COMPETENT COURT

Any dispute arising out of the interpretation, application, execution, termination of the contract and/or of these "**General Terms and Conditions of Sale**" or in any case relating thereto, shall be deferred exclusively to the jurisdiction of the Court where the Seller has its registered office, even in the event of connected cases. The applicable law in all cases is Italian law.

## 15. DATA PROCESSING

The Buyer declares having received the information on data processing pursuant to EU Regulation No. 2016/679 (GDPR) and Legislative Decree 30.06.2003, no. 196 (Personal Data Protection Code), as amended by Legislative Decree 10.08.2018, no. 101.

## ANNEX A

# RULES ON THE HANDLING, MANIPULATION AND STORAGE OF INSULATED METAL PANELS, CORRUGATED SHEETS AND ACCESSORIES

## 1. PACKING AND PACKAGING

**Section 9.10.1 of UNI 10372: latest revision in force** is mentioned in full (text in italics).

*“To maintain their durability in service, metal roofing elements must not be damaged during storage, transport, handling and installation. It is therefore advisable to provide temporary product protection systems for the required performance, especially of an aesthetic nature.*

*During manufacture, these materials are generally protected with polyethylene film (single-contact adhesive) or other solutions.*

*During the subsequent phases, precautions must be taken to ensure the following:*

- *protection of the surface from abrasion, especially during handling;*
- *protection of corners and edges against impact and crushing;*
- *protection against the stagnation of water or condensed moisture;*
- *protection of the elements supporting the mass of the entire package, or of stacked packages, against permanent deformation.*

*Profiled sheets and panels are generally packaged in bundles. The number of sheets in the package is such that the total weight of the package is within the limits imposed by the available lifting and transport equipment.*

*Generally, the materials used for packaging are: wood, expanded plastic materials, cardboard, polyethylene film (heat-shrinkable or stretchable) or others; bindings are made with straps (never with wire) and appropriate protections (edge protectors, etc.). Straps must not be used as lifting slings.”*

Product packages must therefore always be equipped with a support system that distributes the weight evenly and makes it possible to grip the package for handling.

By way of non-limiting example, the support system may consist of foam plastic or dry wood joists or even sheets of composite materials, placed at spacing appropriate to the characteristics of the product.

Packaging must be appropriately defined in the order depending on the mode of transport (e.g. cage or crate for transport involving transshipment, transport by rail or sea). Depending on the performance required of the product or the *Buyer's* needs, an appropriate type of packaging must be provided. This service will be economically quantified when placing the order.

Packages will be packaged according to parameters set by the manufacturer. Any different subdivision of the elements and/or special packaging, depending on specific requirements of the *Buyer*, must be agreed upon when placing the order.

## 2. TRANSPORT

**Section 9.10.2 of UNI 10372: latest revision in force** is mentioned in full (text in italics).

*“Packages must be transported by suitable means so that:*

- *the packages are placed on spacers, made of wood or expanded plastic, placed at a distance from each other appropriate to the characteristics of the product;*
- *the support surface is compatible with the shape of the package (flat if the package is flat, if the package is curved a support must be created that maintains the same curvature);*
- *the overlapping of packages is always done by interposing appropriate spacers, if not present in the packaging, made of wood or expanded plastic;*
- *the packages do not have overhangs of more than 1 m;*
- *the points at which they are to be sling for lifting are clearly marked on the packages if they are not otherwise identifiable;*
- *any other requirements of the manufacturer are complied with.”*

In particular, parcels should be placed flat and wooden or plastic foam spacers of appropriate size and number should be placed underneath them.

Packages shall be secured by the carrier to the means of transport by means of transverse ties with straps placed at a maximum distance between centres of 3 m and in any case each package shall have no less than two transverse ties.

Loading must take place on a free and clean platform. Vehicles with an unsuitable platform or already partially occupied by other materials that prevent safe loading will not be accepted.

The goods on the vehicles are placed under the supervision and approval of the transporter, who is solely responsible for the integrity of the load during transport. The transporter must take particular care to ensure that the pressure exerted by the tying points does not cause damage and that the straps do not cause permanent deformation of the product. Special loading conditions may only be accepted upon written proposal by the *Buyer*, who assumes full responsibility.

## 3. STORAGE

**Section 9.10.3 of UNI 10372: latest revision in force** is mentioned in full (text in italics).

*“The shape of the elements is also designed to allow storage by overlapping in order to minimise storage and transport space; however, care must be taken that no surface damage occurs in the overlap.*

*Packages must always be kept raised off the ground both in the warehouse and, even more, on the construction site; they must have supports preferably made of wood or expanded plastic materials with flat surfaces that are longer than the width of the sheets and at a distance appropriate to the characteristics of the product.*

*The support surface must be compatible with the shape of the parcels; flat if the parcel is flat, if the parcel is curved a support must be created that maintains the same curvature.*

*The packages must be stored in non-humid places, otherwise stagnation of condensation water, which is particularly aggressive on metals, will occur on the less-ventilated inner elements, resulting in the formation of oxidation products (e.g. white rust for zinc).*

*The packages must be stored in such a way as to facilitate water run-off, especially when it is necessary to store them temporarily outdoors.*

*If storage is not followed shortly by removal for installation, it is a good idea to cover the parcels with protective tarpaulins.*

*Attention must be paid to possible electrochemical corrosion phenomena resulting from contact between different metals even during the storage period.*

Generally, it is preferable not to overlap the parcels; if it is considered possible to overlap them due to their low weight, spacers made of wood or expanded plastic with a support base as wide as possible and in an adequate number, always arranged at the supports of the parcels underneath, should always be interposed' (see figure).

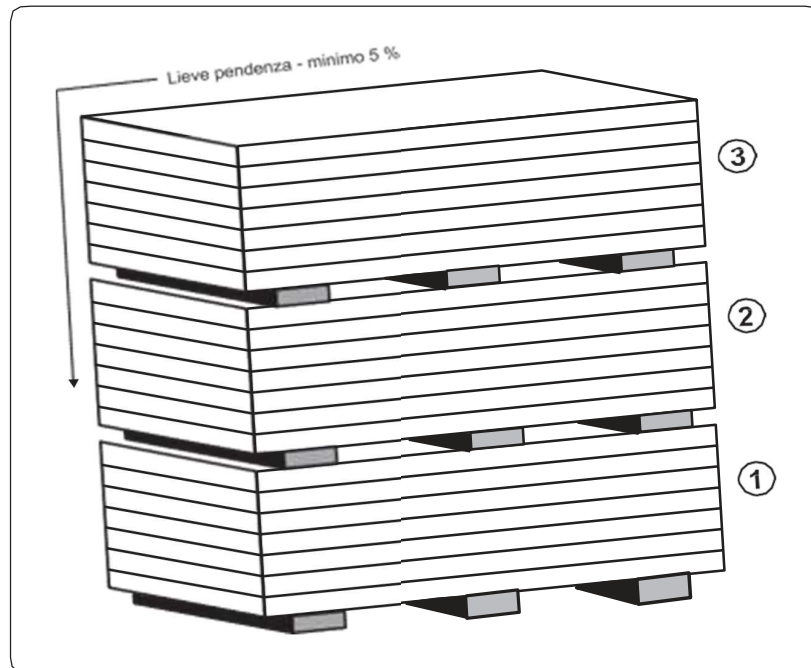

The best storage conditions are in closed, lightly ventilated, moisture-free and dust-free rooms. In any case, and in particular for storage on the construction site, it is necessary to provide a suitable, stable support surface that does not allow water to stagnate.

Parcels must not be placed in areas close to work (e.g. metal cutting, sandblasting, painting, welding, etc.) or in areas where transit or parking of operating vehicles may cause damage (impacts, splashes, exhaust gases, etc.).

A maximum of three packages may be stacked on top of each other, with a total height of approximately 2.6 metres, and in this case it is necessary to adequately thicken the supports.

If the materials are covered with protective film, this must be completely removed during assembly, and in any case no later than 15 (fifteen) days from the date of "notice of ready goods" and provided that the parcels are stored in a shady, covered, ventilated place protected from all types of weather. Any further specific instructions from the supplier must be followed.

In order to maintain the original performance of the product, it is advisable, in accordance with these standards, not to exceed six months of continuous storage in a closed and ventilated environment, while storage in the open air should never exceed two weeks. The materials must always be protected from direct sunlight, as this can cause deterioration. During assembly, panels subjected to sunlight suffer a bowing that makes assembly difficult, so it is recommended to shade the parcel in use.

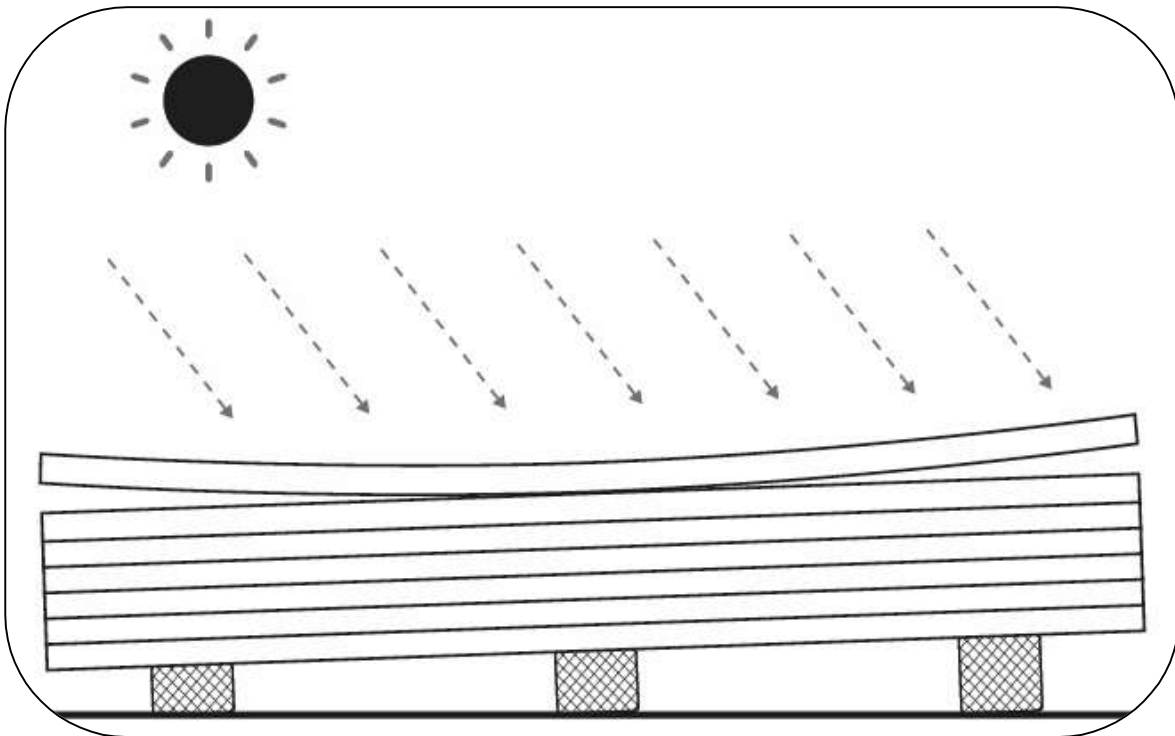

In the case of tarpaulin protection, both impermeability and adequate ventilation must be ensured to avoid condensation and the formation of water pockets.

#### 4. LIFTING AND HANDLING

**Section 9.9.4 of UNI 10372: latest revision in force** is quoted in full (text in italics).

*The parcels must always be sling at least two points not less than half the length of the parcels. Lifting should preferably be carried out with synthetic fibre (nylon) woven straps with a width of no less than*

10 cm so that the load on the strap is distributed and does not cause deformation (see figure). Special spacers must be used below and above the parcel, consisting of sturdy flat elements of wood or rigid plastic material protected by softer material to prevent direct contact of the straps and damage to the panel in the parcel.

These spacers must be at least 4 cm longer than the width of the package and not less than the width of the strap. In any case, the lower spacers must be wide enough to prevent the weight of the pack from causing permanent deformation of the lower elements.

Care must be taken to ensure that slings and supports cannot move during lifting and that manoeuvres are carried out carefully and gradually.

Packages must only be deposited on the roof structure on surfaces that are suitable for support and safety, also in relation to other work in progress. It is advisable to always ask the construction management for permission to deposit.”

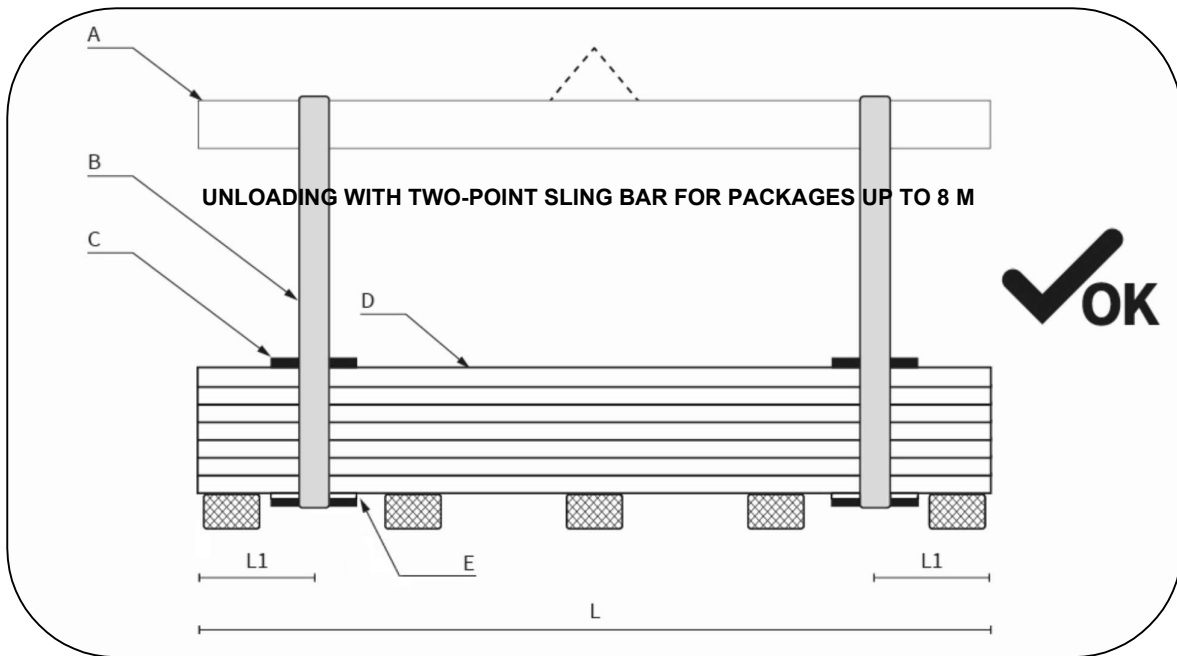

A - Sling bar  
B - Straps woven with synthetic fibre

C - Wooden or plastic spacers  
D - Parcel  
E - Wooden spacers + soft element



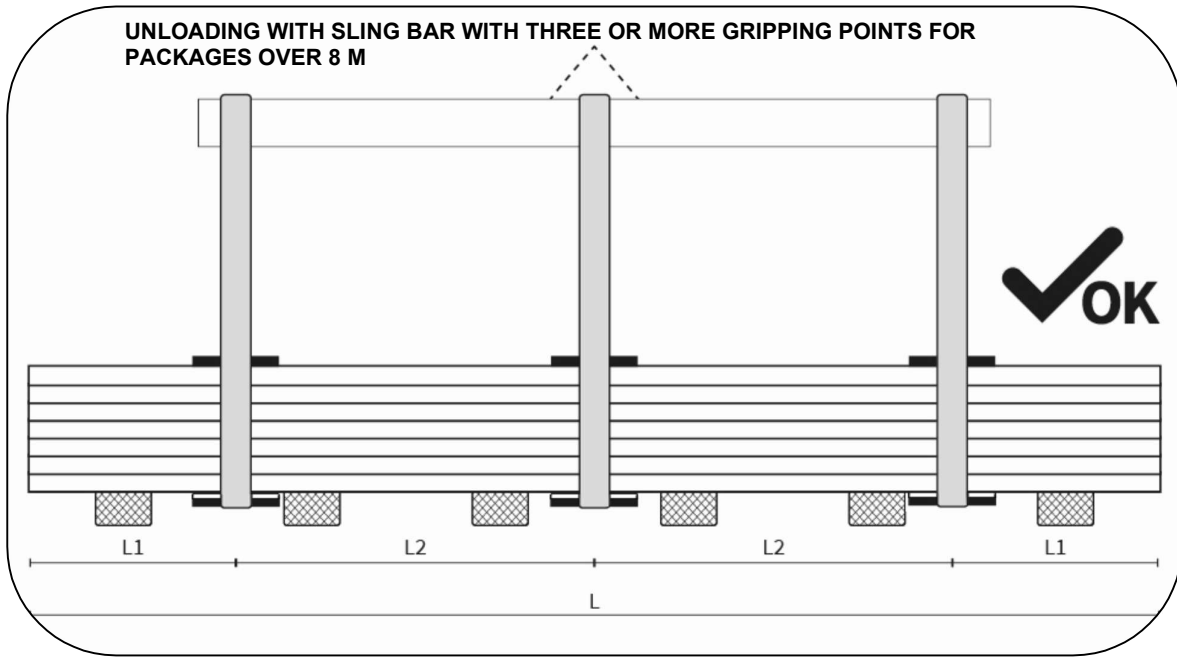

*Gripping of parcels in the wrong manner such as using incorrect and/or incorrectly dimensioned gripping equipment or without considering the correct distance of the gripping points can lead to alterations and consequent damage to the panels in the parcel.*

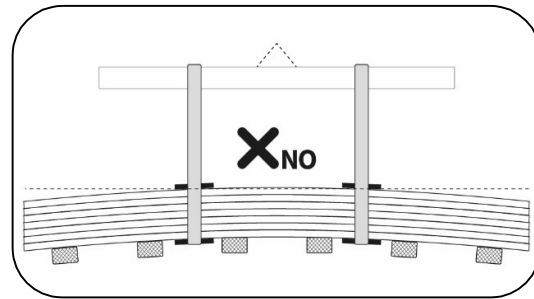
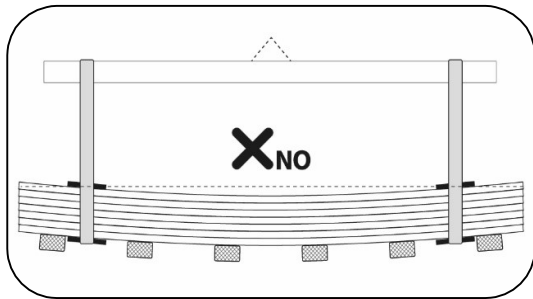

In the absence of a sling bar, in some cases unloading can also take place using suitable forklift trucks. In order to avoid damage to the panel or even breakage of the parcel, the lifting equipment must have fork spacing and fork width that take into account the parcel length, weight, and thickness of the panels that affect the bending of the parcel.

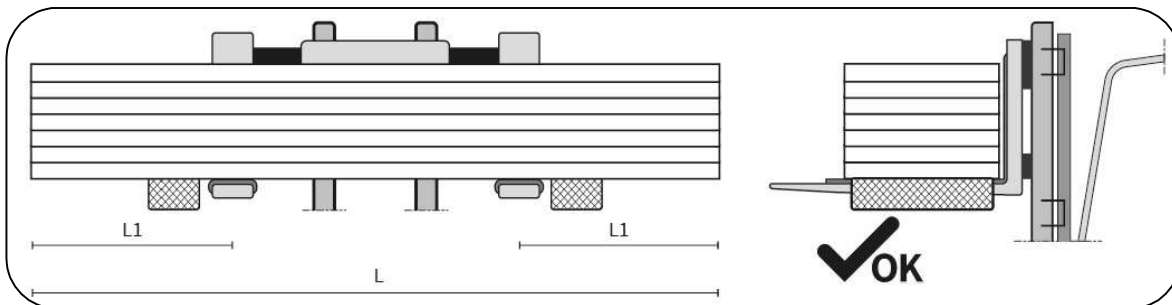

If the parcel is lifted in an unbalanced manner, not taking into account the correct gripping points, there is a risk of consequences such as the parcel falling or the panels being deformed and damaged.

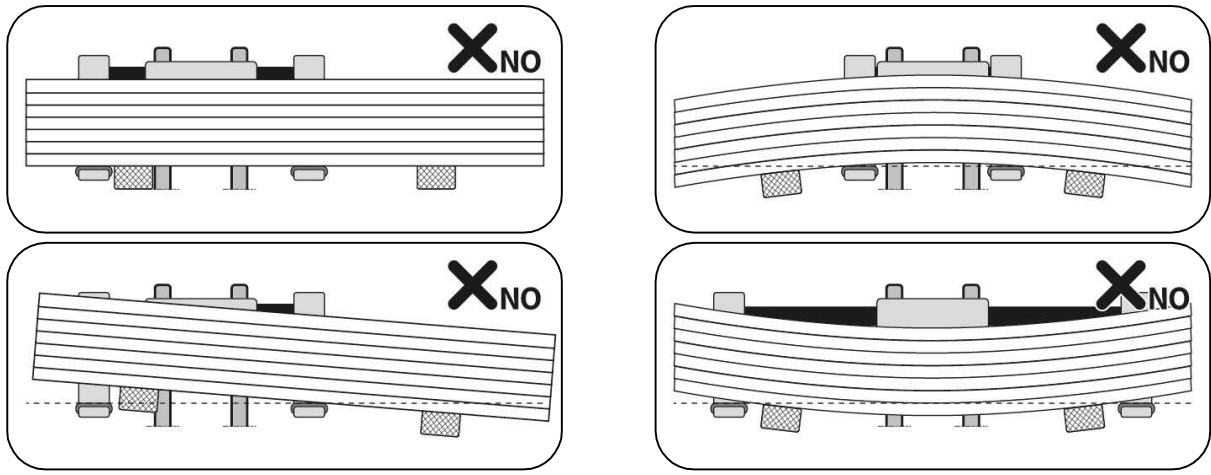

Handling of panels on site must be carried out with suitable lifting systems that have been adequately designed and dimensioned so as not to cause damage to the material during assembly.

Handling of the elements must be carried out using appropriate means of protection (gloves, safety shoes, overalls, etc.), in accordance with the regulations in force.

Manual handling of the individual element must always be carried out by lifting the element itself without sliding it over the lower element and, if necessary, by rotating it by the side of the parcel, taking care not to damage the longitudinal joint of the panel; transport, if by hand, must be carried out by at least two persons depending on the length.

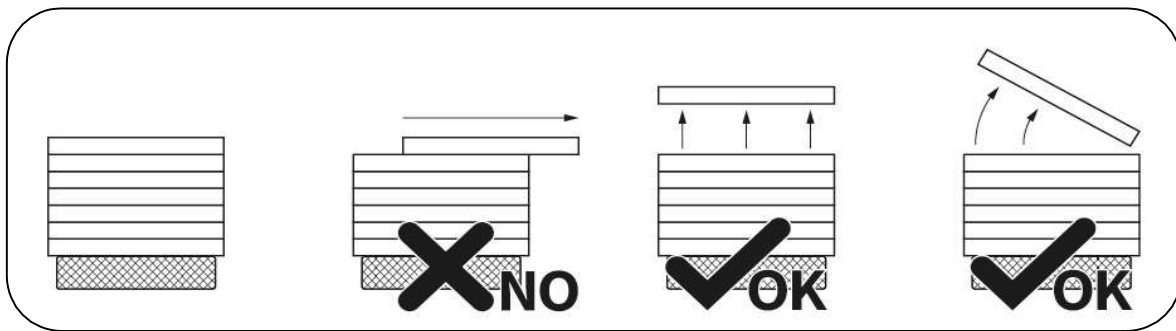

Gripping equipment, as well as work gloves, must be clean and such that no damage is caused to the elements. The use of forklift trucks for handling the elements is not recommended, as this will cause damage. The packages stored at height must always be properly secured to the structures.

*If necessary, depending on the size and weight of the individual panel, it is advisable to provide suitable mechanical lifting devices, such as suction cup lifters or special grippers/jaw clamps.*

*If suction cup systems are used, an adequate distribution and number of suction cups in relation to the surface area and weight of the panel must be provided; the system must be equipped with suction cups suitable for lifting sandwich panels, e.g. that can support the possibility of inserting special pads inside the suction cups to prevent the metal support from detaching. When present, the protective film on the metal support must be removed prior to the application of the suction pads, at least in the affected portion.*

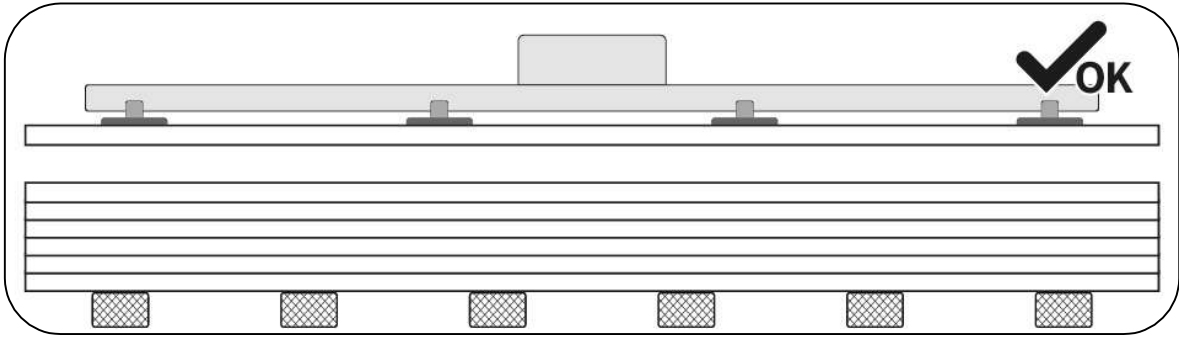

The study and analysis of the suction cup systems to be used is essential to avoid damaging the panels, so it is advisable to design suitable solutions by also discussing with the suppliers of the systems as experts in the field. Failure to design the lifting system can lead to panel breakage as a result of panel imbalance.

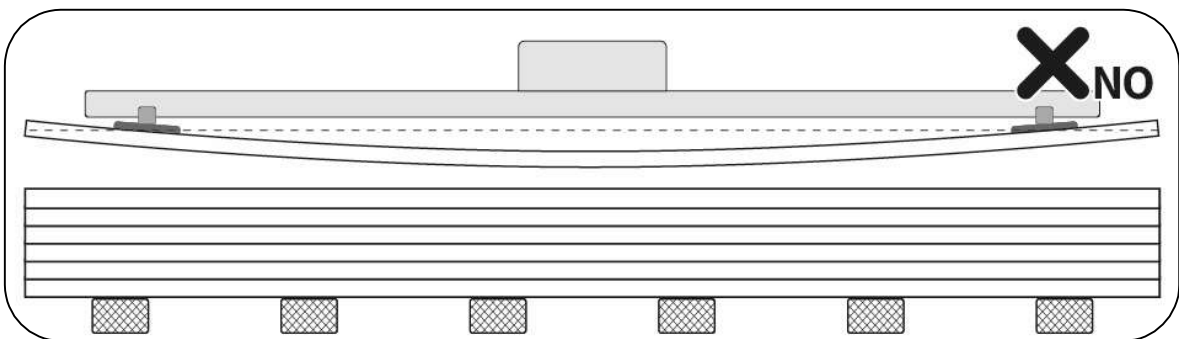
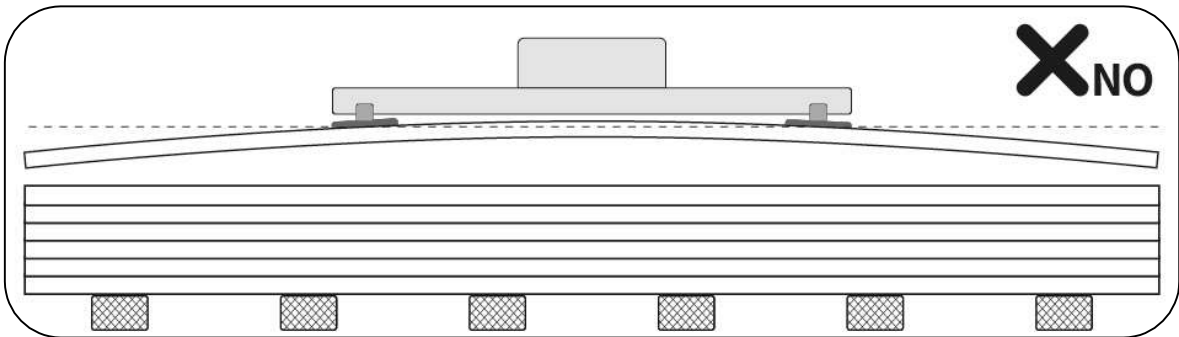
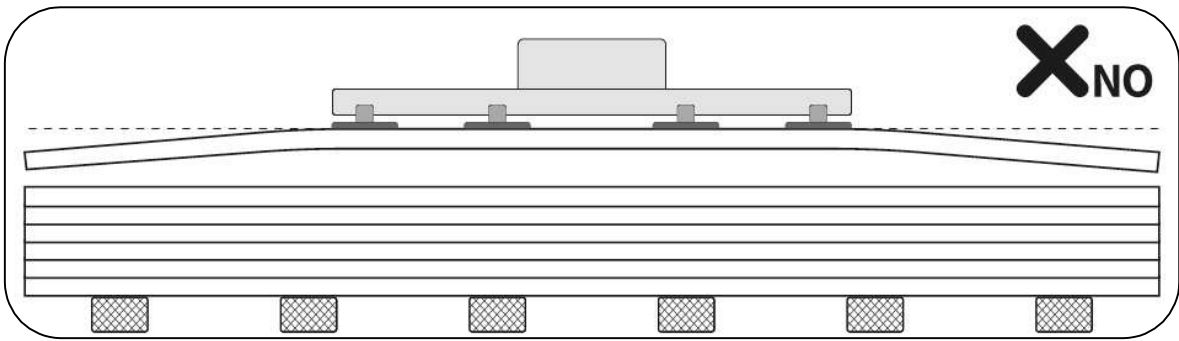

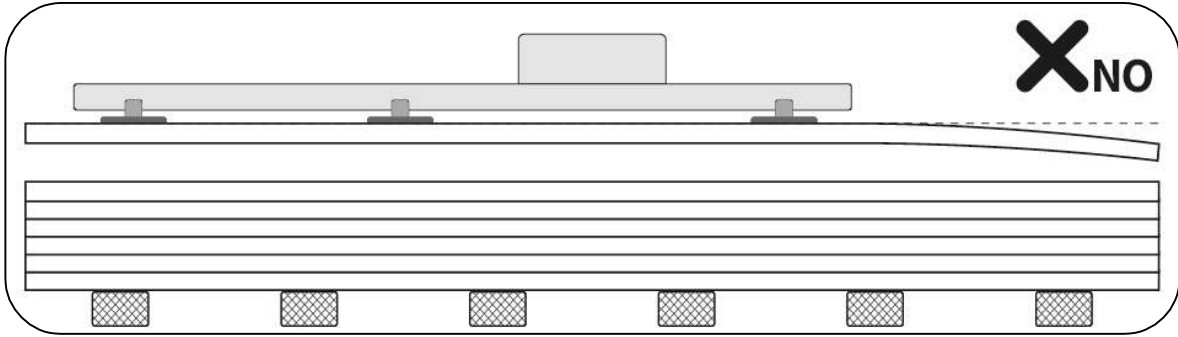

The following are, by way of example, two conceptual solutions for correct suction cup systems in which the suction cups are properly distributed according to the length of the panel.

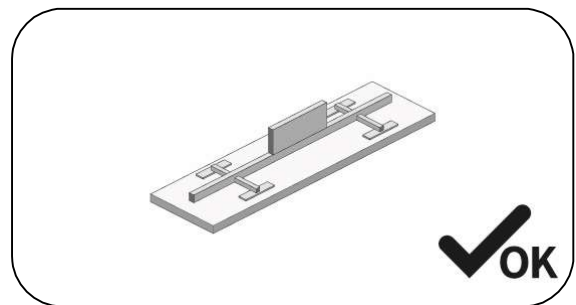
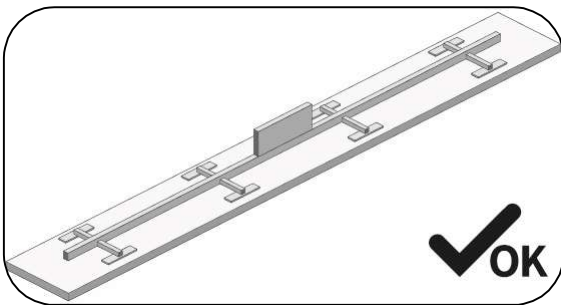

## ANNEX B

### QUALITY STANDARDS OF INSULATED METAL PANELS AND CORRUGATED SHEETS

Corrugated sheets and insulated metal panels are used for walls, roofs and floors of civil and industrial buildings. The quality standards specified in this Annex must be agreed upon in advance between the *Buyer* and the *Seller* in the order confirmation. The aesthetic factor is outside the scope of the products' characteristics and is not a current supply requirement.

The harmonised European product standards, which are valid for the acquisition of the **CE marking**, are **UNI EN 14782:2006** and **UNI EN 14783:2013** for corrugated metal sheets, **UNI EN 14509:2013** for insulated metal panels with double sheet and **ETAG 016** for insulated metal panels with single sheet.

(In order to make Annex A easier to understand, and to reduce the possibility of inconsistencies, misunderstandings and constraints related to the regulations cited, in relation to the current production standard, we suggest lightening the content of the three tables by removing references to standards that are not binding)

MATERIALS	STANDARD	REFERENCE	VALUE-NOTE
<b>1. CORRUGATED SHEETS</b>			
<b>1.1 FEATURES</b>			
1.1.1 Carbon steel	UNI EN 14782:2006		
	UNI EN 14783:2013		
	UNI EN 508-1:2014	3.2 and 4.2	
	UNI EN 10346:2015		S250GD DM ( <i>min. yield strength = 250 N/mm<sup>2</sup></i> )
	UNI EN 10346:2015		Non-structural steels
	UNI 10372: latest revision in force		
1.1.2 Aluminium	UNI EN 14782:2006		
	UNI EN 14783:2013		
	UNI EN 508-2: 2019	3.2 and 4.2	Alloys: Seller's Declaration ( <i>min. tensile strength = 150 MPa</i> )
	UNI 10372: latest revision in force		
	UNI EN 573-3:2019 2022	3.	
	UNI EN 1396:2015	5.	
1.1.3 Stainless steel	UNI EN 14782:2006		
	UNI EN 14783:2013		
	UNI EN 508-3:2008	3.2 and 4.2	Type 1.3401 (AISI304)
	UNI 10372: latest revision in force		
	UNI EN 10088-1:2014	4.	
	UNI EN 10088-2:2014	6.	This Corrigendum to the Standard: EC 1-2008 UNI EN 10088-2:2005

1.1.4 Copper	UNI EN 14782:2006		
	UNI EN 14783:2013		
	UNI EN 506:2008	3.2 and 3.4	Type: declaration by the Seller (unless specifically requested by the Buyer and accepted by the Seller)
	UNI 10372: latest revision in force		
	UNI EN 1172:2012	4 - 5 - 9	
	UNI EN 1173:2008	3.	
	UNI EN 1412:2017	4.	This Corrigendum to the Standard: EC 1-2013 UNI EN 1412:1998
1.1.5 Metal Coatings	UNI EN 508-1:2014	3.2 and 3.4	
	UNI EN 10346:2015		
	UNI 10372: latest revision in force		Including differentiated coatings
1.1.6 Organic coatings (pre-painted and plastic-coated)	UNI EN 10169-1:2012 2022		
	UNI EN 508-1:2014	Annex B	UNI EN 508-2-3:2008
	UNI 10372: latest revision in force		
	UNI EN 1396:2015	6.	
1.1.7 Multilayer bituminous coatings	UNI EN 14782:2006	Annex A	
	UNI EN 14783:2013	Annex A	
	UNI EN 508-1:2014	3.2.6	
	UNI 10372: latest revision in force		
<b>1.2 DIMENSIONAL TOLERANCES</b>			
1.2.1 Carbon steel	UNI EN 10143:2006		Normal tolerances unless otherwise requested
	UNI EN 508-1:2014	Appendix D	
1.2.2 Aluminium	UNI EN 485-4:1996	3.1	
	UNI EN 508-2: 2019	Appendix B	
1.2.3 Stainless steel	UNI EN 10088-2:2014	6.9 - Annex B	
	UNI EN 508-3:2008	Appendix B	
1.2.4 Copper	UNI EN 1172:2012	6.4	
	UNI EN 506:2008	Appendix A	
	UNI EN 1172:2012		
<b>1.3 REQUIREMENTS</b>			
1.3.1 Performance	UNI EN 14782:2006		
	UNI EN 14783: :2013		
	M.D. 09.01.1996	Part II	
	M.D. 14.09.2005	11.2.4.8.1.1	
	Regulation (EU) No 305/2011	Chapter II Articles 4-5-6-7-Annex III	Declaration of performance and CE marking
1.3.2 Test methods (coated metal strips)	UNI EN 13523-0:2014 2022		Values and tolerances declared by the Seller
1.3.3 Durability	UNI EN 10169::2022		
	UNI EN 1396:2015		

1.3.4 Fire Behaviour	UNI EN 14782:2006	Annex C	
	UNI EN 14783:2013	Annex B	
1.3.5 Calculation procedures (concentrated loads)	UNI EN 14782:2006	Annex B	
1.3.6 Inspection and Maintenance	UNI 10372: latest revision in force		
	AIPPEG General Terms and Conditions of Sale	Annex D	

<b>2. INSULATED METAL PANELS (DOUBLE SHEET)</b>			
<b>2.1 FEATURES</b>			
2.1.1 Rigid Metal Facing	The same references as in 1.1 above apply (excluding the specific requirements of UNI EN 14782:2006 and UNI EN 14783:2013)		
2.1.2 Insulations			
2.1.2.1 Rigid cellular plastics	UNI EN 13165:2016		PUR and PIR
	UNI EN 13164:2015		Polystyrene
	UNI EN 13172:2012		Evaluation and Compliance
2.1.2.2 Mineral fibres	UNI EN 13162:2015		
<b>2.2 DIMENSIONAL TOLERANCES</b>			
2.2.1 Rigid Metal Facing	The same regulations, references, values and notes as in 1.2 above apply		
2.2.2 Panel	UNI EN 14509:2013	Annex D	
2.2.3 Bubbles	<p>“Bubbles are defined as convex areas with a lack of insulation-wall adhesion. In the absence of regulations, it is considered that, based on experience, any bubbles do not constitute a defect relevant to the functionality of the product. This can have a subjective impact on the aesthetic result for the Buyer. If you wish to reduce this aesthetic impact, you can do so by following the actions recommended by the Seller. Claims due to this phenomenon cannot be considered if the Buyer has not applied a correct product configuration and has not taken into account the recommendations of the Seller listed in section 6.</p>		
<b>2.3 REQUIREMENTS</b>			
2.3.1 Performance	UNI EN 14509:2013		
	UNI 10372: latest revision in force		
	Regulation (EU) No 305/2011	Chapter II Articles 4-5-6-7-Annex III	Declaration of performance and CE marking
2.3.2 Test methods	UNI EN 14509: 2013	Annex A	
2.3.3 Durability	UNI EN 14509:2013	Annex B	
2.3.4 Fire Behaviour	UNI EN 14509:2013	Annex C	
2.3.5 Calculation procedures	UNI EN 14509:2013	Annex E	
2.3.6 Inspection and Maintenance	UNI 10372: latest revision in force		
	AIPPEG General Terms and Conditions of Sale	Annex D	

<b>3. INSULATED METAL PANELS (SINGLE-SHEET)</b>			
<b>3.1 FEATURES</b>			
3.1.1 Rigid Metal Facing	The same references as in 1.1 above apply (excluding the specific requirements of UNI EN 14782:2006 and UNI EN 14783:2013)		
3.1.2 Insulations			
3.1.2.1 Rigid cellular plastics	UNI EN 13165:2016		PUR and PIR
	UNI EN 13164:2015		Polystyrene
	UNI EN 13172:2012		Evaluation and Compliance
3.2 DIMENSIONAL TOLERANCES			
3.2.1 Rigid Metal Facing	The same regulations, references, values and notes as in 1.2 above apply		
3.2.2 Panel	ETAG 016	Part 1 and 2	Values declared by the Seller
3.2.3 Bubbles	Reference Section 2.2.3		
<b>3.3 REQUIREMENTS</b>			
3.3.1 Performance	UNI 10372: latest revision in force		
	Regulation (EU) No 305/2011	Chapter II Articles 4-5-6-7-Annex III	Declaration of performance and CE marking
3.3.2 Other Requirements	ETAG 016	Part 1 and 2	Values declared by the Seller
3.3.3 Inspection and Maintenance	UNI 10372: latest revision in force		
	AIPPEG General Terms and Conditions of Sale	Annex D	



## ANNEX C

# RECOMMENDATIONS FOR THE INSTALLATION OF INSULATED METAL PANELS AND CORRUGATED SHEETS

## 1. BACKGROUND

These Recommendations are intended to provide reference information support for the installation of corrugated sheets and insulated metal panels. They are in any case supplementary to standard **UNI 10372:2013** “*Discontinuous roofs - Instructions for the design, execution and maintenance of roofs made of sheet metal elements*”.

Each job must take into account the needs of the specific site, which will be equipped with the appropriate handling and laying equipment, in accordance with current safety and accident prevention regulations.

The company responsible for the installation of the corrugated sheets/panels must not only be familiar with the characteristics of the materials used, but must also have a qualified workforce suitable for the work on site, ensuring the correct execution of the work in accordance with the project specifications.

Failure to comply with these Recommendations and the improper execution of site operations shall exempt the *Seller* from any liability.

Efficient organisation and coordinated site operations ensure the best conditions for overall work productivity.

## 2. CONSTRUCTION ELEMENTS

Unless otherwise expressly agreed upon in writing with the *Seller*, the items to be supplied do not contribute in any way to the overall or partial stability of the building structure; they are therefore not suitable for bearing vertical - horizontal loads or permanent static loads (excluding their own weight). In fact, they rest on an existing load-bearing structure, which must have been suitably calculated and deemed suitable by the *Buyer* for the positioning and installation of the items, which only perform the function of covering/coating and/or improving the energy level of the building.

A similar prior assessment shall be carried out at the expense and care of the *Buyer* to verify that panels with polyurethane foam insulation are not used in constructions involving excessively high or excessively low continuous operating temperatures that would cause alteration of the main components of the panels.

Corrugated sheets/panels are used in civil and industrial construction for roofing, walls and floors; they are mounted on any type of support structure: metal carpentry, normal and prestressed reinforced concrete, wood.

The supporting structures and their fasteners with corrugated sheets/panels must be adequately dimensioned and must meet the required design conditions with regard to safety, stability and functionality.

The corrugated sheets and insulated metal panels are quick and easy to install, with the possibility of covering the entire length of the roof pitch, i.e. the entire height of the wall or several bays of the ceiling, in a single section. The length of the metal elements is mainly influenced by transport and handling requirements, as well as the nature of the material used and the production technology.

The support surfaces must be compatible with the use and fixing methods of corrugated sheets and insulated metal panels.

The most common types are:

## **A. ROOFS**

- A.1 in corrugated sheet metal
  - A.1.1 in plain corrugated sheet metal
  - A.1.2 in sandwich prepared on site
  - A.1.3 in deck prepared on site
- A.2 in monolithic insulated panels
  - A.2.1 in prefabricated monolithic sandwich
  - A.2.2 in pre-insulated decks

## **B. WALLS**

- B.1 in corrugated sheet metal
  - B.1.1 in plain corrugated sheet metal
  - B.1.2 in sandwich prepared on site
- B.2 in monolithic insulated panels
  - B.2.1 in prefabricated monolithic sandwich

## **C. FLOORS**

- C.1 in plain sheet metal
- C.2 in sheet metal with collaborating concrete
- C.3 in corrugated sheet metal as non-recoverable formwork

The assembly sequences for roofs, walls and floors differ according to their respective types.

### 3. PRELIMINARY OPERATIONS

Before starting the assembly work in the construction site, the installer must:

1. view the project drawings and comply with their requirements;
2. check the alignments of the supporting structures of the corrugated sheets/panels;
3. check that the surfaces of the supporting structures, which will come into contact with the corrugated sheets/panels, are compatible with each other or otherwise protected from possible corrosion due to electrochemical effects;
4. ensure that there is no interference with overhead power lines in the area where the corrugated sheets/panels are manoeuvred;
5. ensure that the work on site and at height is compatible with other site activities;
6. check the suitability of the site area for storing and handling material so that it is not damaged.

The installer must carry out all assembly operations in accordance with and in compliance with current safety regulations. Furthermore, for the lifting, handling and storage at height of corrugated sheets/panels, please refer to section 4 of Annex A.

The installation personnel must be equipped with footwear with soles that do not cause damage to the outer face. Suitable tools (jigsaw, shear, nibbler, etc.) must be used for cutting operations on the construction site. The use of tools with abrasive discs is not recommended.

A torque-limiting screwdriver should be used for fastening operations.

In the case of roofing panels in particular, perfect overlapping and juxtaposition of the elements is necessary to avoid condensation phenomena.

### 4. ROOFS

#### SLOPES

The slope of the roof depends on the environmental conditions, the design solution and the type of roof.

For roofs with pitch elements without intermediate butt joints (slabs of equal pitch length), the slope to be adopted is usually **not less than 7 %**. For smaller slopes, the supplier's specifications must be adopted.

In the case of butt overlaps, the slope must take into account the type of joint and the material used, as well as the specific environmental conditions.

In the case of deck roofs, the slope may be reduced to the minimum value to allow for regular water run-off.

#### ASSEMBLY SEQUENCES

Here are the essential points of a correct assembly sequence.

##### A) Plain corrugated sheet metal and prefabricated monolithic sandwich (types 1.1.1 and 1.2.1)

1. Installation of guttering and any underlays and flashings.
2. Installation of the roofing elements starting from the eaves and from a lateral end of the building with removal of the protective film, taking care to correctly overlap and align the elements and to check that they are perfectly orthogonal to the underlying structure.
3. Systematic fixing of the elements on site, after checking that they are perfectly matched. Timely removal of all residual materials is required, with particular attention to metal residues.
4. Installation of the successive rows of elements over the eaves (in the presence of a pitch in two or more elements). In the case of panels, the insulation in the overlap area must first be removed.
5. Fastening at all corrugations on ridge lines, eaves, ridges and headers.
6. Installation of completion elements (ridges, flashings and guttering in general) and any related insulation.
7. Total removal of residual materials and general inspection of the roof, paying particular attention to the fastenings and the areas of connection with the other elements making up the roof.

## **B) Sandwich prepared on the construction site (type 1.1.2)**

### **B.1) Parallel corrugated sheet sandwiches**

1. Installation of the guttering and flashings: this can be carried out, according to the project specifications, before laying the inner sheet metal or before installing the outer sheet metal.
2. Installation of the roofing elements starting from the eaves and from a lateral end of the building with removal of the protective film, taking care to correctly overlap and align the elements and to check that they are perfectly orthogonal to the underlying structure.
3. Systematic fastening of the elements on site, after checking that they are perfectly matched. Prompt removal of all residual materials is necessary, with particular attention to metal residues.
4. Installation of the successive rows of elements over the eaves (in the presence of a pitch in two or more elements).
5. Fastening at all corrugations on ridge lines, eaves, ridges and headers.
6. Installation of rigid spacers appropriately dimensioned and positioned according to the project. In the case of metal spacers, a thermal break should be provided between the spacers and the external corrugated sheet metal. If the secondary support structure allows for the direct housing of the inner sheet, the aforementioned rigid spacers are superfluous.
7. Installation of the insulation (taking care to ensure the uniformity of the thermal insulation), of any layers with a specific function (e.g. vapour barrier, separator layer, etc.) and of any header 'pads'.
8. Installation of external sheet metal, according to the sequences 2. to 6. of item 8.1).
9. Total removal of residual materials and general inspection of the roof, paying particular attention to the fastenings and the areas of connection with the other elements making up the roof.

## B.2) Crossed corrugated sheet sandwiches

1. Installation of the roofing elements starting from the eaves and from a lateral end of the building with removal of the protective film, taking care to correctly overlap and align the elements and to check that they are perfectly orthogonal to the underlying structure.
2. Systematic fastening of the elements on site, after checking that they are perfectly matched. Prompt removal of all residual materials is necessary, with particular attention to metal residues.
3. Installation of guttering elements concerning the first sheet (underlays, fittings, special elements).
4. Installation of rigid spacers properly sized and positioned as per the project. In the case of metal spacers, a thermal break should be provided between the spacers and the external corrugated sheet metal. If the inner sheet is made of staves, spacers are not necessary, but a thermal break should always be provided.
5. Installation of the insulation (taking care to ensure the uniformity of the thermal insulation), of any layers with a specific function (e.g. vapour barrier, separator layer, etc.) and of any header 'pads'.
6. Installation of external sheet metal, according to the sequences 1. to 7. of item A) Plain corrugated sheet metal.

## C) Deck prepared on the construction site (type 1.1.3) and Pre-insulated Deck (type 1.2.2)

The installation requirements for internal sheets of item B) apply. Seam fastening must be performed along the longitudinal overlaps.

For decking performed on site, the insulation is guaranteed by the insulation applied afterwards.

For pre-insulated decking, fixings must be carried out after temporary local removal of the insulation.

Sealing is guaranteed by the layers applied subsequently (bituminous sheathing or synthetic membrane, etc.).

## 5. WALLS

### ASSEMBLY SEQUENCES

Here are the essential points of a correct assembly sequence.

#### A) Plain corrugated sheet metal and prefabricated monolithic sandwich (types 2.1.1 and 2.2.1)

1. Installation of the base guttering (when included) at the foot of the wall aligned with the plane of the supporting frame, as well as the guttering that must necessarily be installed before the wall (upper drip moulding, connections with openings, internal corner pieces, etc.), after removal of any protective polyethylene film.
2. Installation of the elements from the foot of the wall, with removal of the protective film, taking care to ensure that they are joined and aligned correctly and that they are plumb.
3. Systematic fastening of the elements on site, after checking that they are perfectly matched.
4. In cases where the height of the wall or the nature of the material implies the need to lay successive rows of elements in a vertical development, the joint is made at a secondary beam of the roof frame and the following procedure must be followed:
  - **flat panel:** butt joint with the insertion of a suitably shaped flashing;
  - **corrugated panel and corrugated sheet:** as a flat panel or by overlapped part.
5. Installation of the finishing elements (corners, perimeter edging, connections with the roof and openings, etc.).
6. General inspection and cleaning of the wall, paying particular attention to fastenings and connections with the window and door frames and other wall components. In the case of walls with horizontally positioned corrugated sheets/panels, reference must be made to the design specifications.

## **B) Sandwich prepared on the construction site (type 2.1.2)**

### **B.1) Parallel corrugated sheet sandwiches**

1. Installation of the base guttering (when included) and of any flashings: this can be carried out, as per the project, before installing the inner sheet or before installing the outer sheet, after removal of any protective film.
2. Installation of the elements from the foot of the wall, with removal of the protective film, taking care to ensure that they are joined and aligned correctly and that they are plumb.
3. Systematic fastening of the elements on site, after checking that they are perfectly matched.
4. If the height of the wall or the nature of the material implies the need to lay successive rows of elements in vertical development, the joint is made by overlapping the same wall elements at a secondary beam of the roof frame.
5. Installation of rigid spacers properly sized and positioned as per the project. In the case of metal spacers, a thermal break should be provided between the spacers and the external corrugated sheet metal. If the secondary support structure allows for the direct housing of the inner sheet, the aforementioned rigid spacers are superfluous.
6. Installation of the insulation (taking care to ensure the uniformity of the thermal insulation) and any layers with a specific function (e.g. vapour barrier, separator layer, etc. according to the particular needs of the building use). This operation must be carried out at the same time as installing the inner sheet metal.
7. Installation of external sheet metal according to the sequences 2. to 5. of section 8.1).
8. Installation of the completion elements (corners, perimeter edging, connections with the roof and walls, etc.).
9. General inspection and cleaning of the wall, paying particular attention to fastenings and connections with the window and door frames and other wall components.

### **B.2) Crossed corrugated sheet sandwiches**

1. Installation of the sheets starting from the foot of the wall, with removal of the protective film, taking care to correctly join and align them.
2. Systematic fastening of the elements on site, after checking that they are perfectly matched.
3. Installation of guttering elements concerning the first sheet (fittings, special elements).
4. Installation of rigid spacers properly sized and positioned as per the project. In the case of metal spacers, a thermal break should be provided between the spacers and the external corrugated sheet metal. If the inner sheet is made of staves, spacers are not necessary, but a thermal break should always be provided.
5. Installation of base guttering (when provided) at the foot of the wall.
6. Installation of the insulation (taking care to ensure the uniformity of the thermal insulation) and layers, if any, with a specific function (e.g. vapour barrier, separator layer, etc. according to the particular needs of the building use). This operation must be carried out at the same time as the installing of the outer sheet metal.
7. Installation of external sheet metal according to the sequences 2. to 5. of section 8.1).
8. Installation of the completion elements (corners, perimeter edging, connections with the roof and walls, etc.).
9. General inspection and cleaning of the wall, paying particular attention to fastenings and connections with the window and door frames and other wall components.

## 6. FLOORS

### ASSEMBLY SEQUENCES

Here are the essential points of a correct assembly sequence.

#### A) Plain sheet metal (type 3.1)

1. Installation of perimeter flashings, if required.
2. Installation of the sheet metals, taking care to ensure that they are correctly matched or overlapped. Also check for perfect alignment and squareness to the underlying structure.
3. Systematically fasten the elements in place in accordance with the design specifications, after checking that they are perfectly joined; also perform seam fastening along the longitudinal overlaps. It is necessary to remove all residual materials with particular attention to metal residues.
4. Completion of the floor in accordance with the design requirements, avoiding burdening the floor elements with concentrated loads.

#### B) Sheet metal with collaborating concrete (type 3.2)

1. Assembly of the concrete containment elements.
2. Installation of the sheet metals, taking care to ensure that they are correctly matched or overlapped. Also check for perfect alignment and squareness to the underlying structure.
3. Systematically fasten the sheet metals in place in accordance with the design specifications, after checking that they are perfectly aligned; also perform seam fastening along the longitudinal overlaps. It must be ensured that the corrugated sheets are free of oxide and oil stains or other substances that prevent adhesion with the concrete mix. It is necessary to remove all residual materials with particular attention to metal residues.
4. In order to avoid concrete dripping at the butt joints of the corrugated sheets, a sealing tape should be provided.
5. Positioning of the electrowelded mesh and/or reinforcing bars, if any, at the supports or supplements, according to the design specifications.
6. Casting the concrete mix, avoiding piling up especially in the central area of the span.
7. In the event that the design prescriptions provide for the use of section-breaking props, these must obviously be positioned before the casting phase, giving the corrugated sheets the required counter-bracing, if any.

#### C) Corrugated sheet metal as non-recoverable formwork (type 3.3)

1. Assembly of the concrete containment elements.

The assembly requirements for item B) apply, except for section 5. where reinforcement bars are obviously mandatory.

## 7. FASTENERS

The fasteners are an essential part of the roof, wall and floor system. It is therefore necessary to use the fasteners specified by the corrugated sheet/panel manufacturer.

Correct installation must include:

#### For roofs:

outer face (types 1.1.1 - 1.1.2 - 1.2.1): a complete assembly generally consisting of screws, cap and associated gaskets, to be placed on the crest of the rib;

inner face (types 1.1.2 - 1.1.3 - 1.2.2): screw with gasket if necessary.

**For walls:**

outer face (types 2.1.1 - 2.1.2- 2.2.1): screw with gasket inner face (types 2.1.2): screw with gasket if necessary; prefabricated monolithic panels with “concealed” fastening: specific fastening unit.

**For floors:**

screws, nails, washer to be welded in place.

The density and positioning of the fixings depends on the characteristics of the building element, the type and size of the supports, and the local climatic situation (windiness in particular). In any case, reference must be made to the design specifications.

In the most common situations, the fastening of corrugated sheets/panels is carried out using screws that differ according to the type of support structure.

**Fastening on metal carpentry:**

- self-threading and thread-rolling/self-tapping screws (depending on the thickness of the substrate)
- self-drilling screws
- shot nails (for floor slabs and internal sandwich sheets in place)
- threaded hooks with nut (generally for anchoring on tubular elements)

**Fastening on woodwork:**

- wood screws threaded hooks

**Fastening on reinforced concrete and prestressed concrete:**

- It is implemented on steel or wooden support elements by means of the types described in 1. and 2. above.

Direct fastening on reinforced concrete and prestressed concrete is not recommended.

For deck and floor coverings, seam fixings, generally using rivets, must be used along the longitudinal overlap with seam fixings spaced no greater than 1000 mm apart.

For other roof and wall elements, seam fastening is advisable, depending on the morphology of the overlap.

## 8. FINISHING ELEMENTS

The finishing elements are an integral part of the structure and make a decisive contribution to ensuring the performance characteristics of the project.

The manufacturer of corrugated sheets/panels is generally able to supply the completion elements, which are to be used according to the design and/or supply specifications.

The *Buyer* must define the typological range of complementary elements of its interest according to the requirements of use. The manufacturer of corrugated sheets/panels is only liable for the conformity of materials to the order confirmation for those parts directly supplied and correctly used.

Finishing elements include variously shaped gaskets, guttering (ridges, under-ridges, eaves channels, ridges and downpipes, flashings, drips, corners, etc.), translucent sheets, domes, ventilators, window frames and accessory components.



## ANNEX D

### INSTRUCTIONS FOR THE INSPECTION AND MAINTENANCE OF ROOFS AND WALLS MADE OF INSULATED METAL PANELS AND CORRUGATED SHEETS

All constructions require systematic periodic inspection and scheduled maintenance to ensure that the building's functionality and performance requirements are maintained over time.

The check during the inspection is intended to cover the roof and wall elements as well as the complementary works present (joints, fasteners, ridges, flashings, snow stops, gutters, downpipes, ...) and any technological installations present (chimneys, smoke evacuators, exhaust fans, lightning protection, ...).

#### 1. INSPECTION

- 1.1. During and as soon as the installation of the insulated metal panels or corrugated sheets is complete, it will be the responsibility of the installation company to remove all material that is no longer required, including possible traces of the temporary protection film. In particular, the contractor shall take the utmost care and attention in removing metal shavings and abrasive elements deposited on the roofing.
- 1.2. However, the handover of the works may only take place after the envelope (roofing and/or walls, including completion elements and in particular the eaves) has been adequately cleaned and free of any foreign material.

Inspections must be carried out at regular intervals, with the first one obligatorily coinciding with the handover of the works carried out or with the relevant test.

The test can be aimed either at the functionality of the specific intervention (roof and/or wall) or at the building as a whole in accordance with the project requirements or in accordance with the contractual relationship between the supplier or general contractor or assembly companies with the client.

Inspections should occur every six months (preferably in spring and autumn of each year).

In the first inspection, which is the responsibility of the installation company or the general contractor or the client/owner according to specification or agreement between the parties, it is to be checked that no foreign materials or scraps have been left behind that could lead to corrosion or damage to the building envelope, or that could impede the proper drainage of rainwater.

In any case, it is necessary to check that an accumulation of undesirable substances such as dust, sand, leaves, etc. cannot occur. It is also advisable to point out to the client/owner potential weak points (see absence of surface protection) on the entire envelope that could generate sources of corrosion (see electrochemical corrosion) with consequent phenomena of premature deterioration also with regard to the aesthetic appearance of the building (see rust drippings).

Another observance is the location of the building: the type of atmosphere existing at the site must be pointed out to the client/owner, also with regard to possible sources (see fumes) of accelerated corrosion from adjacent buildings (the type of existing atmosphere must be known before purchasing materials).

Subsequent inspections consist of a check on the general condition of the envelope: state of preservation (durability) and functionality of both the corrugated sheets and/or insulated metal panels and all the finishing and/or complementary elements, including ridges, flashings, gutters, tightness of fixings, any seals, that may affect the building envelope, monitoring the progression of ageing, both physiological and pathological, in order to plan any ordinary and extraordinary maintenance work that may be necessary.

At the same time, the efficiency of the rainwater drainage system and other technological installations must be checked.

## 2. MAINTENANCE

- 2.1. The building envelope, like any other work, must be periodically inspected in order to detect any problems that are about to occur in good time and to be able to deal with them promptly, thus minimising the burden of maintenance.

Maintenance work is also to be carried out on the main completion works (see anchoring devices and interface with the supporting frame) and secondary works (see rainwater downpipe inlets) that may compromise the overall functionality of the envelope.

- 2.2. Scheduled routine maintenance must be established and carried out by and at the expense of the owner in terms of extent and frequency depending on the results of inspection visits as well as the existing environmental situation and operating conditions of the building. It is in any case aimed at maintaining or adapting the functional requirements of the envelope.

Regular cleaning of the surface of the roof and wall may be sufficient, as may localised work due to faults, nicks and damage.

Any patches of dirt denote the evaporation of liquids that have washed away the surfaces; therefore, in the maintenance phase, in addition to eliminating them, it is necessary to eliminate the cause of the stagnation (e.g. sagging in the gutters, settling of the carpentry, crushing of the ridges and flashings, etc.).

- 2.3. Should the outcome of the inspections lead to the discovery of ongoing conservation problems, it is necessary to proceed with extraordinary maintenance, at the care and expense of the property, in order to restore the initial conditions.

The interventions are aimed both at the onset, early and not assessed at the design stage, of corrosion phenomena on the metal elements, and at the general situation of the envelope compromised by completion works that do not respond in terms of durability or deriving from non-relevant factors (e.g. expansion, ageing, condensation, electrochemical incompatibility, new sources of pollution, change of use, etc.).

These Instructions govern the contractual relationship between the *Seller* party and the *Buyer* party (invoice header). Failure to carry out inspection and maintenance work and incorrect execution shall exempt the *Seller* from any liability in the period from the time of shipment of the material to the time limits for its hypothetical involvement within the relevant legal terms (Art. 1495 Italian Civil Code - Leg. Decree no. 24 of 2 February 2002).

The *Buyer* party undertakes in person to comply with and to cause third parties to comply with the adoption of these Instructions, always limited to the *Seller's* obligations under applicable law (prescriptions, limitations, forfeiture).

Third parties interested and involved by the *Buyer* are understood to be: trading companies, construction companies, assembly operators, contracting and commissioning authorities, property owners and subsequent owners who may intervene in property transfers.

Inspection and maintenance is undertaken by the *Buyer* party vis-à-vis the *Seller* party. The *Buyer* party shall in turn transmit this undertaking when it in turn becomes the *Seller* party and so on in succession until ownership of the property.

For the validation of the inspection and maintenance works, the owner must in any case sign the acceptance to carry out, at its own care and expense, the inspection and maintenance works to be reported in chronological order on a special register with all the technical findings as well as the description of the ordinary maintenance works and extraordinary maintenance works, if required.

This register is established at the initiative of the owner and is maintained and updated by the owner or by its delegation by the building administrator. The register must be available and accessible as a document of regular management of the property, always within the *Seller's* legal terms.

The register must record the deliveries of insulated metal panels and corrugated sheets with the name of the supplier, the details of the order confirmation, the type and characteristics of the material (also catalogue references), the date of deliveries to the construction site and the relevant travel documents, and the subsequent installation history.

The names (and locations) of the designer, construction manager, site safety manager, tester, general contractor, assembly company (or individual operators) must also be entered in the register.

Therefore, the identification and traceability of supplies must be ensured for the entire duration of the validity of these Instructions, which expire with the termination of the relationship with the company producing the insulated metal panels or corrugated sheets as a possible legal involvement.



**Unione Nazionale delle Industrie delle Costruzioni Metalliche dell'Involucro e dei serramenti**  
**Via S.G.B. de La Salle, 4/4a - 20132 Milan - Phone 023192061 - Fax 0231920632**  
unicmi@unicmi.it – [www.unicmi.it](http://www.unicmi.it)